



Life Sciences

Validation Guide

USTR 1029c⁽³⁾

Validation Guide for Pall 0.2 μm Nylon 66 membrane cartridges

Contents

Introduction	4
Filter Media	4
1.1 Validation of Pall Ultipor N66 NRP Grade Production Filters as 0.2 µm Bacterially Rated Filters	5
Introduction	5
Parameter Determination	5
Validation Bacterial Challenge Procedure	6
Results	9
Conclusion	9
1.2 Operational Bacterial Challenge Testing of 0.2 µm Rated Nylon 66 Filter Cartridges	10
2 Extractables Report and Test Procedures on Ultipor N66 NRP Nylon Filter Elements	16
Introduction	16
Summary of Method	16
Results	16
Conclusions	18
3. Biological Safety Reports and Test Procedures on Ultipor N66 Filter Elements	19
Summary	19
Results	19
4. Appendix I	21
Procedure for Challenging Filters with Standard Test Bacteria	21
1. Culture and Media Preparation	21
2. Organism Identification	23
3. Viable Count	24
4. Equipment	25
5. Equipment Preparation	26
6. Equipment Sterilization and Set-Up	26
7. Challenge Protocol	27
Appendix II	29
Procedure for Determination of Extractables from Filter Elements	29
1. Preparation of Apparatus and Materials	29
2. Procedure A – For Solvents not Sensitive to Air	30
3. Procedure B – For Sensitive Air Solvents	32

Introduction

This guide contains validation data applicable to 0.2 µm microbially-rated Ultipor® N66 and N66 Posidyne® membrane filter cartridges.

The test program included Extractable Tests, Biological Safety Tests, and Forward Flow Integrity Tests with Microbial Retention Tests.

The letter P in the part numbering code indicates that these elements are intended for pharmaceutical service, and that they are manufactured in Clean Room environments, and are subject to stringent quality control, including in-process control, and testing of the elements as follows:

1. Forward Flow Test, on a 100% basis
2. Oxidizables and pH Tests
3. Effluent Cleanliness Test
4. Limulus Amoebocyte Lysate Test
5. Microbial Challenge Tests, on a sampling basis.

Filter Media

The Pall 0.2 µm microbially-rated Nylon 66 media discussed in this Validation Guide include Ultipor N66 NRP; Ultipor N66 NFP; and N66 Posidyne NFZP. All these filter types are based on the same membrane, with the Ultipor N66 NFP and N66 Posidyne NFZP filter cartridges having a higher surface area, 0.8 m² per 25 cm element, than the Ultipor NRP cartridges, 0.46 m² per 25 cm element.

The N66 Posidyne NFZ membranes are manufactured to contain cationic (positively-charged) functional groups throughout the membrane to impart a positive zeta potential in aqueous fluids.

Pall will be happy to supply any additional information you may require. Further information may be obtained from the Scientific & Laboratory Services Department.

1.1 Validation of Pall Ultipor N₆₆ NRP Grade Production Filters as 0.2 µm Bacterially Rated Filters

Introduction

The correlation between a non-destructive integrity test and assurance of bacterial retention is extremely important for filters used in critical fluid processes. Such processes often occur at the terminal production stages, but may also be at key intermediate stages. Examples include filtration sterilization of parenterals, biological liquids and fluids for fermentation.

The industry-accepted, non-destructive tests used to verify filter integrity are the Forward Flow, Pressure Hold and the Bubble Point tests. These tests are performed by applying a preset air pressure to a wetted filter. The Forward Flow and Pressure Hold tests quantitatively measure the sum of diffusive flow and the flow through any pores larger than a specified size. The Bubble Point test is qualitative, and determines only the bulk air flow point of a wetted filter. The Forward Flow and Pressure Hold tests, introduced by Dr. D. B. Pall in 1973, are used in critical applications.

Pall Corporation uses the Forward Flow Test method on a 100% production basis for the non-destructive integrity testing of sterilizing grade filter elements. For integral filters, these Forward Flow values are measured air volume flow rates (cubic centimetres per minute) due to diffusion of air through the liquid film wetting the pores of the filter membrane. Forward Flow measurement may be performed downstream of the wetted membrane under constant test pressure, or on the upstream side of the wetted membrane by measuring the air flow required to maintain constant test pressure.

The Pressure Hold test is a modified form of upstream Forward Flow testing in which the filter housing is pressurized to a predetermined setting, then isolated from the pressure source, and the diffusion of air across the wetted membrane is quantitatively measured as a decay in pressure over a specified period of time. Upstream integrity tests are particularly useful in critical fluid processes since they can be performed without compromising the sterility of the downstream system.

Correlating filter integrity test values with bacterial challenge testing is an empirical process resulting in validation data applicable to the test parameters utilized.

Parameter Determination

Based on numerous bacteria challenge tests during development of Ultipor N₆₆ filters, it was determined that a Forward Flow integrity test pressure of 2760 mbar was suitable for integrity testing water wetted Ultipor N₆₆ 0.2 µm filters, and the maximum allowable Forward Flow value should be set at 8.0 mL of air per minute for a 0.46 square metre NRP grade filter cartridge.

In order to validate the use of 2760 mbar air pressure and a maximum allowable flow of 8 mL/minute, a number of elements were subsequently selected from prototype production. These elements included 14 with Forward Flow values in the target range to 8 mL/min, and 47 cartridges ranging from 8 to 450 mL/minute. These elements were manufactured at three separate production facilities and contained several lots. *Pseudomonas diminuta* challenge tests were run on all of these cartridges in accordance with the procedure below. The resulting data are shown in Table 1.1.

Validation Bacterial Challenge Procedure

The Procedure was designed to replicate an extreme bioburden under aqueous process conditions such that the filter was onstream for 6 to 8 hours and reached a high pressure drop, up to 4 bar, due to blocking during that time. NR filter cartridges of 0.46 square-metre surface area were tested as follows, using the apparatus and materials described in Appendix I.

1. The filter was installed in a housing.
2. The filter was wetted by flowing deionized water through it for 15 minutes at a flow rate of 2 liters per minute.
3. The filter was then Forward Flow integrity tested at 2760 mbar and the test value recorded.
4. The filter in the housing was wrapped for autoclaving, autoclave sterilized at 121 °C for 60 minutes, slow exhaust, and allowed to cool to room temperature.
5. The filter was installed on the test system and aseptically connected to an analysis manifold (see Figure I-1).
6. Valves A, B and C on the analysis manifold were closed and Valve D (Control) was opened.
7. Water flow was initiated at 2 liters per minute and the system was run for 15 minutes as a sterility control check of the test system.

Table 1.1 Comparison of Forward Flow with *P. diminuta* Retention for AB1NRP (0.2 µm rated) Filters

Filter Cartridge Serial Number	Forward Flow 2760 mbar Air (Water/Wet) mL/min	Challenge results 7.6L/min Flow Rate for 6 Hours Total <i>P. diminuta</i> Input 1-3.5 x 10 ¹² Final ΔP = 4.1 bar	
		Sterile Effluent	Titer Reduction
K0140208	2.3	Yes	> 1 x 10 ¹²
K0130107	3.2	Yes	> 1 x 10 ¹²
K0140116	3.4	Yes	> 1 x 10 ¹²
K0130056	3.8	Yes	> 1 x 10 ¹²
K0140207	4.3	Yes	> 1 x 10 ¹²
K0130088	4.6	Yes	> 1 x 10 ¹²
K0140031	4.7	Yes	> 1 x 10 ¹²
K0140018	4.8	Yes	> 1 x 10 ¹²
K0130063	5.5	Yes	> 1 x 10 ¹²
113AFB	5.7	Yes	> 1 x 10 ¹²
K0140205	6.2	Yes	> 1 x 10 ¹²
K1900024	6.6	Yes	> 1 x 10 ¹²
NRC4666	7.1	Yes	> 1 x 10 ¹²
K0140214	7.6	Yes	> 1 x 10 ¹²
K1890121	9.8	Yes	> 1 x 10 ¹²
NRC4658	10.0	Yes	> 1 x 10 ¹²
K1890138	11.5	Yes	> 1 x 10 ¹²
K1890137	13.0	Yes	> 1 x 10 ¹²
K1890123	14.3	Yes	> 1 x 10 ¹²
K1890107	15.5	Yes	> 1 x 10 ¹²
NRC4660	16.2	Yes	> 1 x 10 ¹²
K1900002	16.3	Yes	> 1 x 10 ¹²
NRC4667	17.1	Yes	> 1 x 10 ¹²
NRC4668	17.6	No*	1 x 10 ¹²
020AFA	19.4	Yes	> 1 x 10 ¹²
K1900011	20.6	Yes	> 1 x 10 ¹²
K1890132	20.8	Yes	> 1 x 10 ¹²
K1900046	21.0	Yes	> 1 x 10 ¹²
K1890111	22.0	Yes	> 1 x 10 ¹²
025AFB	23.7	Yes	> 1 x 10 ¹²
K1890131	23.7	No	2.4 x 10 ⁷

Table 1.1 (Continued)

Filter Cartridge Serial Number	Forward Flow 2760 mbar Air (Water/Wet) mL/min	Challenge results 7.6L/min Flow Rate for 6 hours Total <i>P. diminuta</i> Input 1 – 3.5×10^{12} Final $\Delta P = 4.1$ bar	
		Sterile Effluent	Titer Reduction
K1890117	24.6	Yes	$> 1 \times 10^{12}$
K1900013	26.7	Yes	$> 1 \times 10^{12}$
K1900037	27.1	No	9.7×10^8
K1900053	28.0	Yes	$> 1 \times 10^{12}$
090AFD	28.6	No	8.1×10^6
NRC4665	29.7	No	1.2×10^8
111AFD	30.0	No	1.0×10^5
037AFD	31.6	No	1.1×10^6
K1900020	33.3	Yes	$> 1 \times 10^{12}$
K1900051	33.4	Yes	$> 1 \times 10^{12}$
NRC4656	35.7	Yes	$> 1 \times 10^{12}$
102AFD	40.0	No	5.1×10^4
014AFD	40.0	No	1.7×10^6
014ADN	40.0	No	4.7×10^9
NRC4669	45.0	No	3.7×10^{10}
078AFE	46.2	Yes	$> 1 \times 10^{12}$
138AFE	47.5	No	2.3×10^5
K1890127	50.3	No	1.0×10^8
NRC4659	52.6	No	8.3×10^9
NRC4664	54.3	No	4.5×10^5
114AFD	54.5	No	1.6×10^3
139AFD	66.7	No	3.0×10^5
102AFE	67.0	No	7.1×10^4
K1890116	67.6	Yes	$> 1 \times 10^{12}$
095AFE	160	No	9.1×10^3
043AFE	200	No	8.0×10^3
060AFE	203	No	9.2×10^4
043AFD	275	No	3.0×10^4
059AFE	400	No	2.0×10^4
084AFE	450	No	4.8×10^5

* 1 colony detected for filter NRC4668

** All filters giving sterile effluents have Titer Reductions greater than 1×10^{12} ; this value was chosen because it is the maximum challenge at which a 7.6L/min flow rate can be maintained.

- Valves A, B and C were then opened and Valve D was closed. The water flow rate was adjusted to the test flow rate of 7.6 liters per minute and bacterial input was initiated. Analysis membrane D was removed, plated on Mueller Hinton Agar, and incubated at 32 °C for 72 hours.

Note: *P. diminuta* input was by metering pump at a constant rate for the length of the test with the challenge being $1 - 3.5 \times 10^{12}$ viable cells. The water flow rate was maintained at 7.6 liters per minute throughout the test by use of an automatic flow control regulator.

- At the end of the challenge period, when the differential pressure across the test filter reached 4 bar, bacterial input was terminated and water flow was allowed to continue for 10 minutes. The test was then stopped and analysis membranes A, B and C were removed aseptically, plated on Mueller Hinton Agar, and incubated for 72 hours at 32 °C.

Titre Reduction (TR) was calculated using the formula:

$$\text{TR} = \frac{\text{Number of organisms incident on the filter}}{\text{Total Number of organisms on the three test discs}}$$

If the effluent is sterile, TR is greater than 1×10^{12} , and retention is 100%.

- The test filter was again Forward Flow integrity tested and the value recorded. The higher of the two forward flow values was used in tabulating the data of Table 1.1. Any test having a contaminated control analysis membrane was considered invalid, as were tests involving O-ring bypass and improper housing dimensions.

Results

The data from the validation study are listed in order of increasing forward flow values in Table 1.1. The data show that all grade NR filters with Forward Flow values below 17 mL/min retained 100% of the *Pseudomonas diminuta* challenge. Additional data is provided in Table 1.2 which represents current ongoing testing of Ultipor N66 and N66 Posidyne media in various filter styles.

Conclusion

The Forward Flow integrity test maximum value of 8 mL/min per 0.46 m² surface area of an NR filter tested at 2760 mbar, water wet, incorporates a 100% safety factor. Ultipor N66 NR filters which have Forward Flow values equal to or lower than 8 mL/min will provide absolute removal of incident *Pseudomonas diminuta* under the test conditions.

1.2 Operational Bacterial Challenge Testing of 0.2 µm Rated Nylon 66 Filter Cartridges

Pall Corporation routinely samples filters for bacterial challenge testing in its continuing monitoring of Ultipor N66, and N66 Posidyne 0.2 µm rated filter cartridges. The challenge conditions are stated below.

Bacterial Challenge Test Conditions

Flow Rate:	1 liter per minute
Test Time:	60 minutes
Test Liquid:	Water (filtered to 0.2 µm absolute)
Test Bacterium:	<i>Pseudomonas diminuta</i> (ATCC No. 19146), single cells
Total Challenge	> 2 x 10 ⁸ per cm ² effective filtration area. This challenge level will typically cause an increase in the pressure drop due to the on-set of filter blockage.

Representative filters were challenged utilizing the standard procedure set forth in this guide and the test parameters listed in Table 1.2. Forward Flow results are shown in Table 1.3. The filters retained 100% of the challenge influence providing a sterile effluent.

Table 1.2 Forward Flow Test Parameters

Wetting Liquid	Water
Test Pressure	2760 mbar
Filter Part Number	Forward Flow Limit* (mL/min) (Max. Allowable Air Flow)
KA1NFP	2.0
SLK7001NRP	2.3
KA2NFP	3.2
SLK7001NFP	3.5
AB02NFP	4.6
SLK7002NRP	4.6
KA3NFP	5.3
SLK7002NFP/NFZP	7.0
AB1NRP	8.0
KA4NFP	8.0
AB1NFP/NFZP	12.0

* The Forward Flow Test limit has been validated for bacterial removal by correlation of test parameters with microbiological challenge tests. Actual test values for integrity testing of Pall filters as installed must be obtained from Pall.

Table 1.3 Representative 0.2 µm Rated Nylon 66 Production Filters Which Have Undergone Bacterial Challenge Testing and Providing a Sterile Effluent

Filter Part Number	Filter Serial Number	Pre-Challenge Forward Flow at 2760 mbar Air Pressure (Water Wet mL/min)
AB1NFP	BA6420360	2.6
	FA0900718	4.3
	L0686109	4.4
	Y13306603	4.5
	FA127007	4.6
	Y1330005	4.7
	Y0730206	5.2
	FA1240009	5.4
	FA0010124	5.5
	Y1470210	5.6
	Y1870367	6.0
	IA9820101	6.7
	FA1760007	6.9
AB1NRP	FA0240009	2.7
	M5956252	3.1
	B4850250	3.2
	Y0850014	3.4
	FA1850006	3.6
	FA0020009	3.8
	Y1200001	3.9
	Y0370512	4.2
	B5010707	5.0
	K1866516	5.2
Y0670758	5.4	
AB1NFZP	FA200010	4.4
	Y1880441	4.5
	Y1130025	4.6
	Y1120003	5.1
	Y1140004	5.1
	Y1890041	5.9

Table 1.3 (Continued)

Filter Part Number	Filter Serial Number	Pre-Challenge Forward Flow at 2760 mbar Air Pressure (Water Wet mL/min)
SLK7002NFP	D0810322	1.2
	M9896026	1.4
	M04476047	1.4
	K5826441	1.6
	M2586047	1.6
	CD5340591	1.6
SLK7002NFZP	CD2770410	1.6
	CD4470412	2.1
	CD4460333	2.4
	B9500365	2.9
	B9500878	4.2
	CD740840	5.2
SLK7002NRP	CD7460612	1.1
	CD6330400	1.1
	K7916371	1.2
	B7610309	1.5
	CD5010178	1.5
	CD3650175	1.6
	CD4010234	1.6
	M3416296	1.8
SLK7001NFP	CD4110166	0.7
	CD5170061	0.8
SLK7001NRP	B5990575	0.5
	CD5410157	0.6
	IB0060170	0.7
	CD7790225	0.7
	CD3840817	0.8
	B8800716	1.2
	N0896146	1.6

Table 1.3 (Continued)

Filter Part Number	Filter Serial Number	Pre-Challenge Forward Flow at 2760 mbar Air Pressure (Water Wet mL/min)
KA1NFP	IN5880011	0.3
	IN5880018	0.3
	IN5880021	0.6
	IN5880022	0.4
	IN5880032	0.2
	IN5880039	0.8
KA2NFP	IN1410028	0.6
	IN1410029	0.5
	IN1410035	0.4
	IN1410036	0.4
	IN1410052	0.5
	IN1410063	0.5
	IN6450003	0.5
	IN6450005	0.6
	IN6450018	0.4
	IN6450027	0.4
	IN6450031	0.5
	IN6450032	0.5
	KA2NFZP	IM9560006
IM9560010		0.2
IM9560017		0.4
IM9560018		0.4
IM9560022		0.5
IM9560040		0.4

Table 1.3 (Continued)

Filter Part Number	Filter Serial Number	Pre-Challenge Forward Flow at 2760 mbar Air Pressure (Water Wet mL/min)
KA3NFP	PILF210001	2.6
	PILF210002	1.4
	PILF210007	1.5
	PILF210009	1.2
	PILF210011	3.9
	PILF210012	1.6
	PILF214003	1.2
	PILF214005	1.3
	PILF214007	1.7
	PILF214010	1.3
	PILF214011	1.3
	PILF214014	1.2
	K206023	1.5
	IK206029	1.3
	IK206291	1.3
KA3NFZP	PILF197005	1.5
	PILF197008	1.5
	PILF197011	2.7
	PILF197019	2.3
	PILF197039	1.7
	PILF197045	1.4
	IK2070122	2.5
	IK2070172	1.2
	IK2070174	1.2

Table 1.3 (Continued)

Filter Part Number	Filter Serial Number	Pre-Challenge Forward Flow at 2760 mbar Air Pressure (Water Wet mL/min)
KA4NFP	IA0881019	1.2
	IA0881051	1.4
	IA0881023	1.9
	IA0881003	2.2
	IA0881055	2.2
	IA0881010	2.4
	IW1150023	2.5
	IW1150010	2.5
	IW1150021	2.5
	IA0881026	2.3
	IA0881018	2.9
	IW1150006	2.9
	IW1150046	3.1
	IW1150004	3.2
	IA0881046	4.1
	IA0881037	5.1
	IA0881024	10.6

All tested filters gave sterile effluent

2 Extractables Report and Test Procedures on Ultipor N66 NRP Nylon Filter Elements

Introduction

The purpose of this test series was to determine the amount of material which can be extracted from the 0.2 µm microbial-rated Ultipor N66 membrane filter cartridges by water and by commonly used solvents. General Purpose Elements (i.e. NRP) and 'S' option Special Purpose Elements containing 0.46 m² of filter medium surface area were tested as completely assembled 25 cm cartridges without O-rings, adapters or locating fins.

Summary of Method

Representative filter cartridges were autoclaved unwrapped for one hour at 123 °C, using slow exhaust, prior to extraction. A metal basket was used to hold the elements when in the autoclave. Visible droplets of water remaining on the elements after autoclaving were allowed to evaporate at room temperature. Extraction was then performed in the commonly used solvents listed in Table 2, at the temperatures indicated.

Extraction was performed by immersing the filter in 1500 mL of the solvent and gently reciprocating the cartridge up and down. The bottom of the cartridge was plugged; this ensures that flow of the extracting solvent (eluate) takes place through the filter medium as a result of the pressure head of solvent that is created each time the element is partially lifted out of the solvent during extraction. After the extraction, 1000 mL of the eluate was evaporated to dryness and the nonvolatile extractables were determined gravimetrically. The detailed procedure is described in Appendix II.

A visual examination for haze was also performed using a portion of the eluate diluted with deionized water. This was done for solvents which are completely miscible with water; three dilutions of the eluate were made with deionized water: (1) 50 mL eluate + 25 mL water; (2) 50 mL eluate + 50 mL water; and (3) 50 mL eluate + 100 mL water. The dilutions were allowed to stand for ten minutes at room temperature and then observed for haze. As noted in Table 2, the degree of haze was categorised as: (a) clear, or no haze upon dilution with water; (b) slight haze upon dilution with water; or (c) actual precipitation upon dilution with water.

Results

Total weights of non-volatile extractables obtained are reported in Table 2. The quantities listed are in milligrams per filter cartridge as determined on elements containing 0.46 m² of filter surface area.

Table 2 Extractables Levels of Ultipor N66 Pharmaceutical Grade Cartridges

Non-volatile extractables, determined on 0.46 m² cartridges after autoclaving 1 hour at 125 °C, by 4 hour exposure in 1.5 liters of agitated solvent^(a).

Fluid	Temperature	General Purpose Ultipor N66 Elements NRP (milligrams)	Special Purpose Ultipor N66 Elements NRPS (milligrams)
Acetic acid, 70%	20 °C	48 ^(b)	62
Acetone	20 °C	270 ^(c)	28
Acetonitrile	20 °C	240 ^(c)	10
Acetonitrile	reflux (82 °C)	–	31 ^b
Ammonium Hydroxide 28%	20 °C	58	41
Benzene	20 °C	290	52
Benzyl alcohol	20 °C	290	97
N-butanol	20 °C	52	47
N-butyl acetate	20 °C	84	37
Carbon tetrachloride	20 °C	71	69
Carbon tetrachloride	reflux (77 °C)	930 ^(d)	1193 ^(d)
Chloroform	20 °C	1040	94
Chloroform	reflux (61 °C)	7200 ^(d)	390 ^(d)
Dimethyl formamide	20 °C	320 ^(c)	36 ^(b)
Dimethyl formamide	100 °C	–	240 ^(b)
Dimethyl sulphoxide	20 °C	263	58
Dioxane	20 °C	–	98 ^(b)
Ethanol, 3A	20 °C	51	26
Ethanol, abs	20 °C	44	–
Ethanol, abs	reflux (78 °C)	900 ^(c)	84 ^(b)
Ethanol, 50%	20 °C	69	21
Ethanolamine	20 °C	264	106
Ethyl acetate	20 °C	220	24
Ether (diethyl)	20 °C	35	64
Ether (diethyl)	reflux (35 °C)	120	91
Freon TMC	20 °C	920	50
N-heptane	20 °C	22	44

Table 2: (Continued)

Fluid	Temperature	General Purpose Ultipor N66 Elements NRP (milligrams)	Special Purpose Ultipor N66 Elements NRPS (milligrams)
Hydrochloric acid 10%	20 °C	410	245
Iso-propyl alcohol	20 °C	35	52
Methanol	20 °C	41 ^(b)	63 ^(b)
Methylene chloride	reflux (40 °C)	–	79
Methyl isobutyl ketone	20 °C	180	25
Propylene glycol	20 °C	155	30
Pyridine	20 °C	310 ^(c)	35
Trichloroethylene	20 °C	–	71
Water	20 °C	22	19

(a) The conditions yield approximately the same result as obtained by flowing for 4 hours

The data is based on autoclaving the cartridge prior to the test. If not autoclaved, the extractables are lower than listed.

No haze upon dilution with water for water-miscible solvents, unless otherwise noted

(b) Slight haze upon dilution with water

(c) Haze or precipitate on dilution with water

(d) Cartridge may deform, for example, due to swelling of the polypropylene outer cage, but retains integrity

Conclusions

The levels of extractables found for Ultipor N66 membrane filter cartridges are extremely low.

Special Purpose Elements were found to have lower levels of extractables in certain solvents than General Purpose Elements. In visual examination for haze after dilution with deionized water, a slight haze or precipitate was observed with only seven solvents for the General Purpose Elements. No precipitate was observed for the Special Purpose Elements, and a slight haze was observed with only 5 solvents, usually at reflux.

The levels of extractables reported for NR are typical of Ultipor N66 and N66 Posidyne production elements; the levels of extractable reported for NRPS are typical of 'S' option Special Purpose production elements. Some variations from element to element may occur.

Actual service will impose different conditions, such as different exposure times, temperature, solvent purity, etc., hence, evaluation under process conditions is recommended.

3. Biological Safety Reports and Test Procedures on Ultipor N66 Filter Elements

The purpose of these tests was to evaluate the biological stability of the materials of construction of the Ultipor N₆₆ and N₆₆ Posidyne membrane filters. This was done by performing the Biological Tests for Plastics, as described in the *United States Pharmacopeia*, and performing evaluations for mutagenic activity by Ames Test.

Summary

The testing procedure described in the USP include injection of extracts of plastic materials, as well as implantation of the material itself into animal tissue. Four extracting media are listed which simulate parenteral solutions and body fluids. These include: Sodium Chloride Injection, 1 in 20 Solution of Alcohol in Sodium Chloride Injection, Polyethylene Glycol 400, anti Vegetable Oil (sesame or cottonseed oil). Extracts are prepared at one of three standard conditions: 50 °C for 72 hours, 70 °C for 24 hours, or 121 °C for 1 hour. Since Nylon 66 membrane filters will be autoclaved during use, and since the most stringent condition not resulting in physical changes in the plastic is recommended, they were extracted at 121 °C.

An Acute Systemic Injection Test was performed to evaluate the potential of a single injection of an extract to produce systemic toxicity. Sodium Chloride Injection and 1 in 20 Solution of Alcohol in Sodium Chloride Injection extracts were injected intravenously. Vegetable Oil extract and Polyethylene Glycol 400 extract were injected intraperitoneally.

An Intracutaneous Test was performed to evaluate the potential of a single injection of an extract to produce tissue irritation. All four extracts were used.

Implantation was also performed, in order to subject the materials of construction to the most stringent conditions included in USP. Each of the components of the Ultipor N₆₆ membrane filter cartridges was implanted separately. Evaluation for mutagenic activity was performed in a bacterial assay with and without a mammalian activation system. *Salmonella typhimurium* strains were used because their spontaneous mutation frequency is relatively constant, but increases when a mutagen is added to the agar. The strains used were obtained from Dr Ames at the University of California at Berkeley. These strains are particularly permeable to many large molecules and have enhanced sensitivity to some mutagenic agents.

Evaluation for mutagenicity tests were run at a minimum of six dose levels of the test material, ranging over two or three log concentrations. Positive and negative control assays were conducted with each experiment.

Results

The Ultipor N₆₆ and N₆₆ Posidyne membrane filter cartridges were found to meet the requirements of the USP for Class VI (121 °C) Plastics. The tests were conducted by South Mountain Laboratories, 380 Lackawanna Place, South Orange, New Jersey 07079, and the test reports are available on request.

Mutagenicity evaluations of the Nylon 66 membrane filters were performed using the Ames Salmonella/microsome plate test using extracts of the General Purpose filter cartridges, the Special Purpose filter cartridges, and the Nylon 66 membrane filter medium alone. The extracts of each of these were obtained in: distilled Water for Injection (USP), distilled water for Injection (USP) adjusted to pH 3

with hydrochloric acid, distilled water for Injection (USP) adjusted to pH 10 with diethanolamine, 95% ethyl alcohol (USP), and dimethyl sulphoxide (DMSO).

The results of the tests conducted indicate that the filter materials are not mutagenic in any of the assays conducted. The tests were conducted by Litton Bionetics, Inc., 5516 Nicholson Lane, Kensington, Maryland 20795, and the test reports for the cartridges are available on request.

4. Appendix I

Procedure for Challenging Filters with Standard Test Bacteria

1. Culture and Media Preparation

1.1 Preparation of *Pseudomonas diminuta* (ATCC No. 19146) Stock Culture

1.1.1 Reconstitute lyophilized preparations of *P. diminuta*, ATCC No. 19146 from the American Type Culture Collection per ATCC directions. Check the purity of the reconstituted culture via streak plates. Examine for uniform colony morphology, and identify single cell isolates as *P. diminuta* per Section 2.

Prepare stock cultures from single cell isolates. Inoculate Trypticase Soy Agar (TSA) slants and incubate at 30 ± 2 °C for 24 hours.

1.1.2 Long Term Storage of Cultures

Overlay slants with sterile mineral oil and store at 4 °C. Check for viability and purity weekly. Lyophilize or store in liquid nitrogen a culture prepared from 1.1.1.

1.2 Preparation of Frozen Cell Paste of *P. diminuta*

1.2.1 Inoculate 10 mL of sterile Growth Medium A with the stock culture (1.1.1) and incubate at 30 ± 2 °C for 24 hours.

1.2.2 Transfer 10 mL of the bacterial suspension from 1.2.1 into 500 mL of sterile Growth Medium A and incubate at 30 ± 2 °C for 24 hours.

1.2.3 Prepare 10 liters of a seed culture by transferring 200 mL of the bacterial suspension from 1.2.2 into 10 liters of sterile Growth Medium A. Incubate at 30 ± 2 °C for 24 hours.

1.2.4 Inoculate the 10 liters of the seed culture into 500 liters of Growth Medium A. Grow aerobically at 30 ± 2 °C. Monitor growth spectrophotometrically at 500 nm, and plot growth curve.

1.2.5 When the culture reaches the stationary phase, harvest the cells by continuous flow centrifugation.

1.2.6 Resuspend cells in two to three volumes of cold sterile Harvesting Buffer.

1.2.7 Centrifuge suspension and resuspend cells in an equal volume of Harvesting Buffer. Determine the cell concentration. (Expected concentration of viable cells is $2 - 6 \times 10^{11}$ /mL).

1.2.8 Transfer portions, e.g. 50 mL, of cell paste into sterile plastic centrifuge tubes, and freeze using dry ice-acetone bath or liquid nitrogen. Store frozen cell paste at 60 °C or lower.

1.3 Preparation of Stock Suspension from Frozen Cell Paste

1.3.1 Disinfect the tube containing the cell paste by dipping tube in 80% ethyl alcohol and flaming just long enough to burn off most of the alcohol. Use sterile tongs to hold tube.

- 1.3.2 Aseptically remove the cap from the tube and drop the tube into a sterile Erlenmeyer flask containing a sterile magnetic stirring bar and twenty volumes of a sterile solution of 0.9% NaCl which contains 0.002 M MgCl₂ at room temperature, e.g. transfer 50 mL of frozen cell paste into 1 liter sterile solution. **Note:** MgCl₂ must be in the solution prior to adding the frozen cell paste to prevent clumping during thawing.
- 1.3.3 Place the flask on a magnetic stirring unit, and mix until the entire contents of the tube is evenly suspended (30 – 40 minutes). Store up to three weeks in refrigerator at 3 °C.
- 1.3.4 Determine the concentration of viable cells according to Section 3. (Expected concentration of cell suspension is 1 – 3 x 10¹⁰ cells/mL).
- 1.3.5 Identify the organism as *Pseudomonas diminuta* as per Appendix 1, Section 2.

1.4 Preparation of Challenge Suspension

- 1.4.1 Prepare one liter of *P. diminuta* challenge suspension by diluting the appropriate amount of the stock suspension with sterile 0.9% saline and mix well.

Example: Stock titer	= 2 x 10 ¹⁰ /mL
Desired Total Challenge	= 2 x 10 ¹²
Volume of stock required	= 100 mL

To make challenge suspension add 100 mL of stock to 900 mL of sterile saline and mix well.

- 1.4.2 Split challenge volume into two 500 mL portions and store in refrigerator until needed. This volume is sufficient for one test.
- 1.4.3 Immediately prior to starting test, ultrasonically disperse the cells in one of the 500 mL portions (from 1.4.2) by placing the container in a 50 watt ultrasonic cleaning bath and sonicating for 10 minutes. This treatment breaks up cell aggregates, but does not damage the cells.
- 1.4.4 Add a sterile stirring bar to the dispersed suspension, place suspension on magnetic stirring plate, and insert metering pump inlet line. Stir at moderate rate during test.
- 1.4.5 When volume remaining is about 75 to 100 mL, ultrasonically disperse second 500 mL portion of challenge suspension (as in 1.4.3) and add to suspension on stirring unit.

Note: Cells will reaggregate slowly. Sequential addition of freshly sonicated suspension prevents this from occurring during the test period.

1.5 Media Preparation

- 1.5.1 Trypticase Soy Agar (TSA)

Prepare per manufacturer's directions.

1.5.2 Trypticase Soy Broth (TSB)

Prepare per manufacturer's directions.

1.5.3 Growth Medium A. per liter

Trypticase Peptone (or Casitone)	7.5g
Yeast Extract	2.5g
NaCl	0.5g
MgSO ₄	0.002M final

Bring to 1 liter with H₂O, pH 6.8–7.2, autoclave at 121 °C for 15 minutes.

1.5.4 Harvesting Buffer

K ₂ HPO ₄	790 mg
K ₂ HPO ₄	1.0 gram
Glycerol	100 mL
Water	900 mL

Adjust to pH 7.2 with 0.1N KOH, autoclave at 121 °C for 15 minutes.

1.5.5 Mueller Hinton Agar

Prepare per manufacturer's directions.

2. Organism Identification

Identification of *Pseudomonas diminuta* (ATCC No. 19146)

2.1 Colony Morphology

2.1.1 Colonies of *Pseudomonas diminuta* are yellow-beige, slightly convex, shiny and entire.

2.1.2 At 30 °C colonies are microscopic to pinpoint at 24 hours, and 1 to 2 mm diameter at 36 to 48 hours.

2.2 Microscopic Examination

2.2.1 Prepare a gram stain.

2.2.1.1 Examine the preparation with a compound light microscope fitted with a calibrated ocular micrometer and an oil immersion objective lens with good resolving power (e.g., a planachromatic objective with an N.A. of 1.2 or greater). Observe several microscopic fields for organism size and arrangement of cells.

2.2.1.2 Stained preparation should reveal a gram negative, small, rod-shaped organism about 0.3 to 0.4 µm by 0.8 to 1.0 µm in size, occurring primarily as single cells.

2.2.2 (Optional) Prepare a flagella stain. *Pseudomonas diminuta* is characterized by a single, polar flagellum.

2.3 Biochemical Characterisation

2.3.1 Perform the following biochemical tests to assure that the organism is positively identified as: *Pseudomonas diminuta*.

2.3.2 Alternatively, commercially available systems for bacteria identification may be used for identification of *Pseudomonas diminuta*.

Test	Results
Spore Formation	-
OF glucose medium, open	-
OF glucose medium, sealed	-
Indole	-
Methyl red	-
Acetylmethylcarbinol	-
Gelatinase	-
Aerobe	+
Catalase	+
Cytochrome (Indophenol oxidase)	+
Growth on MacConkey Agar	+
Denitrification	+
DNase (DNase Test Agar)	-
Centrimide tolerance	-

3. Viable Count

Viable Count of *P. diminuta* Stock and Challenge Suspensions

3.1 Aseptically remove a sample from the prepared suspension of *Pseudomonas diminuta*

3.2 Aseptically prepare decimal serial dilutions of the suspension

3.3 Perform viable colony assay, in duplicate, using the standard membrane filter assay procedures as follows:

Use 1 mL from each of the 10^{-7} to 10^{-10} dilutions of the frozen cell stock suspension, and from each of the 10^{-6} to 10^{-9} dilutions of the challenge suspension. Place 20 mL of sterile saline into the funnel of the filter holder prior to adding the 1.0 mL sample of the decimal dilutions. Filter and wash the walls of the funnel with 20 mL of sterile saline.

3.4 Transfer analysis membranes to petri plates containing TSA and incubate assay plates at 30 ± 2 °C for 72 hours

3.5 Count colonies on plates showing between 12 and 100 colonies, and calculate the concentration (cells/mL) of the original suspension

4. Equipment

Note: All system piping, unless otherwise noted, is type 304 stainless steel (SS).

4.1 System Upstream of Test Filter

- 1 – Ball Valve, 1/2 in. NPT, Type 304 SS
- 1 – Pressure Gauge, 0 – 10 bar, SS, Marshalltown 89917
- 1 – Pressure Regulator, 8.3 bar, bronze or SS
- 2 – Sanitary Connectors, Tri-clover 23 BMP, 1 in. Thermometer caps, Type 304 SS
- 3 – Clamps, Tri-Clover 13 MHHA, 1 1/2 in., Type 304 SS
- 2 – Sanitary Housing, Pall Corporation, SANT 1G723
- 4 – Ball Valves (Vent and Drain), 1/4 in. NPT, SS
- 1 – Flow Rate Controller (Automatic), Kates Type MFA, 1 – 14 L/min, 316 SS, 1/2 in. NPT
- 1 – Metering Pump, Fluid Metering Inc., RPG-6-1-CSC (1/4 in. ceramic piston), and Low Flow Teflon Tube Fittings Kit, Teflon Tubing 1/8 in. OD x 1/16 in. ID.
- 1 – Quick Connect Body, Swagelok SS-QCS-B8PF-VT with Viton O-ring, 1/2 in. NPT, SS

4.2 Test Filter Assembly

- 1 – Quick Connect Stem, Swagelok SS-QC8-S8PT, 1/2 in. NPT, SS
- 1 – Sanitary Connector, Tri-Clover 23 BMP, 1 in. Thermometer Cap, Type 304 SS
- 2 – Clamps, Tri-Clover 13 MHHA, 1 1/2 in., Type 304 SS
- 1 – Sanitary Housing, Pall Corp., SANT 1G723
- 1 – Indicating Pressure Switch, 0 – 10 bar, 1/4 in. NPT, U.S. Gauge # 19029
- 1 – Vent Valve, needle type, 1/4 in. NPT, SS
- 1 set – Quick Connect Body and Stem, Swagelok, SS-QC-4-S4PF and SS-QC4BM4PM-VT, SS

4.3 Analysis Manifold

- 1 – Sanitary Connector, Tri-clover 23 BMP, 1 in. Thermometer Cap, Type 304 SS
- 1 – Clamp, Tri-Clover 13 MHHA, 1 1/2 in., Type 304 SS
- 1 – Hose Connector, 1/2 in. I.D., Hose barb to 1/2 in. NPT, SS
- 1 – Hosing 12 mm I.D. Tygon, reinforced, 450 mm long
- 1 – Pressure Gauge, 0 – 2 bar, Marshalltown 89917 (severe service gauge) 1/4 in. NPT
- 4 – Ball Valves, Hoke Rotoball Barstock (#7223F8V), 1/2 in. FNPT – 1/2 in. FNPT, with Viton O-rings
- 4 – Hose Connectors, 3/8 in. I.D. Hose barb to 1/2 in. NPT, SS
- 4 – Filter Disc Holders, 142 mm diameter, Type 304 SS
- 4 – Hosing, 8 mm I.D., reinforced Tygon, 300 mm long.

4.4. Analysis Membrane Filters

- 4 – Membrane Filter Discs, 0.2 µm, 142 mm diameter.

5. Equipment Preparation

5.1 Assemble the equipment listed within each sub-section above, e.g. 4.1 (Use Figure I-1 as guide)

5.1.1 Wet the O-rings of the test filter cartridge with water prior to installing the filter in its housing.

5.1.2 Install the 142 mm analysis membrane filter discs (0.2 µm) in the housings.

5.2 Pre-Challenge Integrity Test of Test Filter

5.2.1 Install the filter in its housing and flush with 0.2 µm filtered water at a flow rate of 2 liters per minute for 15 minutes. Open the vent on the test filter housing upon initiating flush to completely fill test filter housing, then close the vent.

5.2.2 Perform the Forward Flow integrity test using a test pressure of 2760 mbar g. Record integrity test value (mL/min) obtained.

6. Equipment Sterilization and Set-Up

6.1 Analysis Membrane Filters in Housings

6.1.1 Connect a short piece (200 – 250 mm) of autoclavable tubing to vents (vent valves open), and a 300 mm length of reinforced or pressure resistant autoclavable tubing to the inlet port.

6.1.2 Wrap all open ports and ends of tubing with autoclave paper.

6.1.3 Autoclave at 123 °C or 30 minutes, slow exhaust. Allow to cool to room temperature, then close vent valves.

6.2 Analysis manifold with pressure gauge

6.2.1 Open all valves on manifold.

6.2.2 Wrap all open ports and connecting tubing with autoclave paper.

6.3.2 Autoclave at 123 °C for 30 minutes. Allow to cool at room temperature.

6.3 Test filter in housing

6.3.1 Wrap inlet, outlet and vent (open) with autoclave paper

6.3.2 Autoclave the test filter in its housing for 60 minutes at 123 °C, slow exhaust.

6.4 Aseptic Assembly of Sterilized Equipment (Refer to Figure I-1)

6.4.1 Connect the test filter inlet to the test stand.

6.4.2 Aseptically connect the test filter outlet to the analysis manifold.

6.4.3 Aseptically connect each of the analysis membrane filters to the analysis manifold.

Figure I-1 Test Set-up for Bacterial Challenge Test

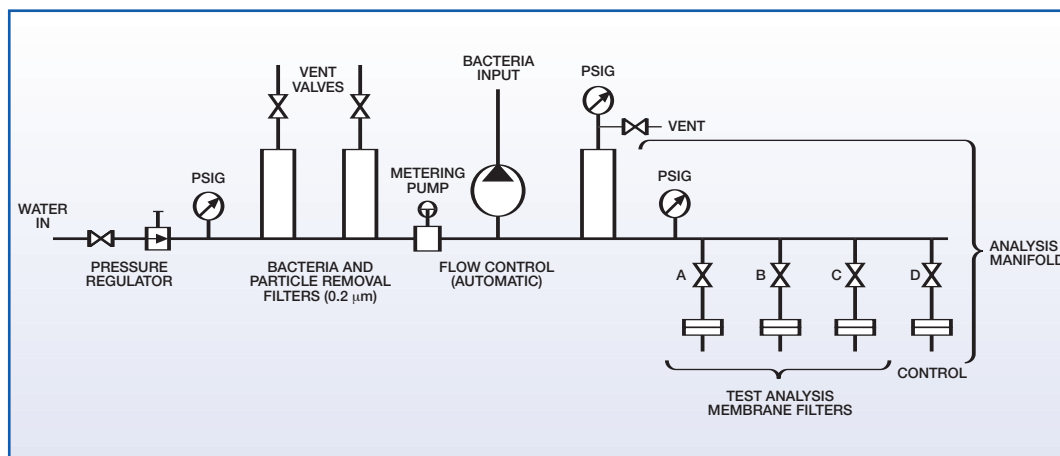

7. Challenge Protocol

7.1 Negative Control (performed immediately prior to Bacterial Challenge).

7.1.1 Connect a piece (~150 mm long) of tubing to the vent valve on the test filter housing to facilitate venting.

7.1.2 With valves, A, B, C closed and Valve D (control) open, flow water through the test filter and control analysis filter at a flow rate of 2 liters per minute for 15 minutes.

7.1.3 Open valves, A, B and C and close valve D. Vent the air from each test analysis filter holder

7.1.4 Aseptically remove the control analysis filter holder and transfer to laminar flow hood.

Note: This should be done before starting bacterial test challenge. Then start challenge per Section 7.2 and continue with 7.1.5 and 7.1.6.

7.1.5 Apply vacuum to downstream side of control analysis filter holder to remove residual liquid.

7.1.6 Aseptically transfer the control analysis filter disc to a Mueller Hinton Agar Plate and incubate at 32 °C for 72 hours.

7.2 Bacterial Challenge

7.2.1 Adjust the system flow rate to 7.6 L/min for each 0.46 m² filter.

7.2.2 Connect the tubing from the positive displacement metering pump, and the bacteria suspension, to the water line upstream of the test filter.

7.2.3 Start the positive displacement (metering) pump to reject the bacteria suspension (prepared per Section 1) into the water feed. The pump rate is adjusted to provide the total bacteria challenge over the test time of approximately 6 hours. Bacterial input is stopped when the pressure drop across the test filter reaches > 4 bar d, giving a total challenge of 1 – 3.5 x 10¹² viable organisms. System flow is continued for 10 additional minutes.

- 7.2.4 Shut off water flow and then close valves A, B and C.
- 7.2.5 Aseptically remove each test analysis filter holder and transfer to laminar flow hood.
- 7.2.6 Apply vacuum to the downstream side of each test analysis filter holder to remove residual liquid.
- 7.2.7 Aseptically transfer each test analysis filter disc onto a labelled Mueller Hinton Agar Plate and incubate at 32 °C for 72 hours. If colonies appear, count and perform identification per Appendix I, Section 2.
- 7.2.8 Post challenge integrity test: repeat the Forward Flow integrity test on the test filter using the test pressure of 2760 mbar g. Record value obtained.

Appendix II

Procedure for Determination of Extractables from Filter Elements

1. Preparation of Apparatus and Materials

It is essential that care be taken to prevent the filter cartridge, the eluate and subsequently, the non-volatile residue from being contaminated with any material which does not originate in the filter itself. Therefore, all apparatus used in this test must be scrupulously clean, and the solvents used must be sufficiently pure so that any non-volatile impurities in the solvent do not contribute significantly to the non-volatile residue, obtained upon evaporation of the eluate. Solvents containing more than 2 mg/liter non-volatiles (as determined by steps A III.1 or B III.1 of this procedure) should be purified prior to use, preferably by distillation. This tests exists in two modifications: Procedure A for solvents not sensitive to air, and Procedure B for solvents sensitive to air. Filter cartridges used in these procedures were 25 cm in length, completely assembled, but without O rings, adapters and locating fins.

Figure II-1 Tie Rod and Plug Assembly

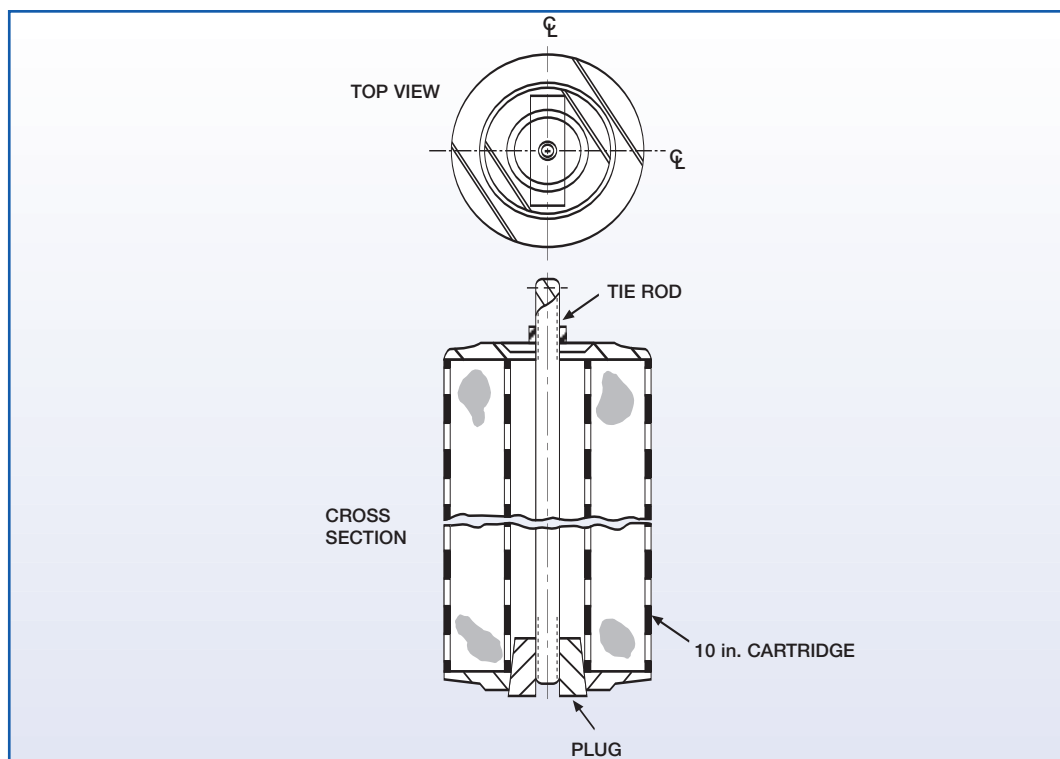

2. Procedure A – For Solvents not Sensitive to Air

2.1 Equipment Required

1. 2 liter Pyrex graduated cylinder, cleaned with chromic acid
2. 1500 mL solvent
3. Aluminium foil
4. 12 rpm motor with eccentric cam, having a 7.5 cm stroke during full cycle, and vertical shaft with hanger
5. Tie rod and plug assembly (see Figure II-1)
6. Rotary evaporator
7. Vacuum pump capable of maintaining pressures of < 1 mm Hg (for high boiling solvents)
8. 25 mL platinum crucible
9. Circulating air oven
10. Vacuum oven (for high boiling solvents)
11. 3 liter resin kettle (or other flask) with heating mantle
12. Reflux Condenser

2.2 Extraction Procedure

1. Fit cartridge with tie rod and plug assembly (see Figure II-1).
2. Fill graduated cylinder to 1500 mL mark with solvent. For extraction at elevated temperatures, substitute a 3 liter resin kettle equipped with a heating mantle and reflux condenser.
3. Immerse cartridge into the measured solvent slowly, allowing all entrained air to escape.
4. Attach shaft of motor to the tie rod assembly (see Figure II-2).
5. Adjust apparatus so that cartridge is submerged at least 10 mm at downstroke, and emerges at least 20 mm at upstroke.
6. Cover graduated cylinder with aluminium foil, slotted to accommodate hanger from cam. For extraction at elevated temperatures, position the hanger through the reflex condenser.
7. Reciprocate for 4 hours at room temperature or other temperature desired.
8. At the end of the 4 hours remove the filter cartridge from the liquid, allow the solvent to drain into the cylinder, remove the cartridge, and cover the graduated cylinder.

9. If further testing of the cartridge is required, the cartridge should be retained. If no immediate testing is required, rinse the cartridge by successively drawing 2000 mL acetone and 2000 mL Fotocol 190 through it, and allow the cartridge to air dry overnight. When dry, seal the cartridge in a plastic bag.

Figure II-2 Attachment of Tie Rod Assembly to Motor Drive Disc

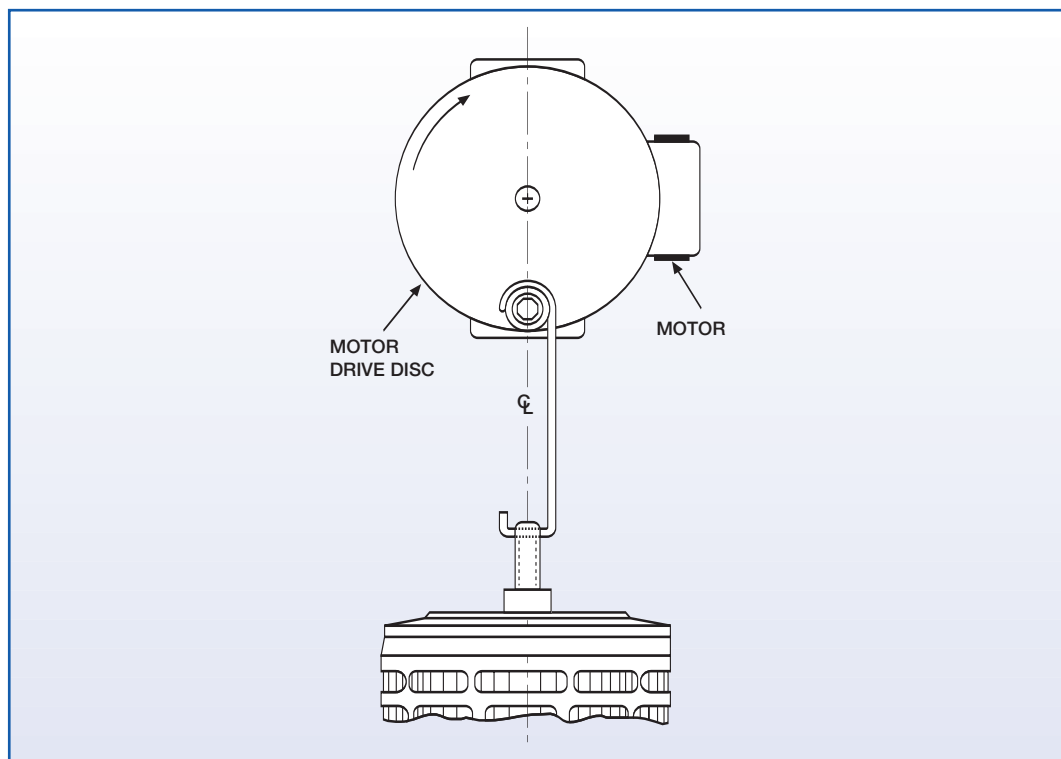

2.3 Procedure for Determination of Non-volatile Residue

1. Determine solvent blank by allowing 1500 mL pure solvent to remain in a clean graduated cylinder for 4 hours at room temperature and determine the non-volatile residue in the same manner as the following procedure for the filter eluate (i.e. steps 2 – 8 below).
2. Transfer approximately 250 mL of the eluate into a clean container to be used as a retention sample (e.g. in visual examination for haze after dilution with deionized water), allowing 1000 mL to remain in the graduated cylinder. Note that approximately 250 mL of the eluate is retained by the filter cartridge.
3. Concentrate the 1000 mL sample to less than 25 mL by transferring it into a round-bottom flask and using a rotary evaporator at aspirator pressure. CAUTION: Aspirator must be located in a vented hood, as the solvent vapours will be delivered in its effluent.

Bath temperature during evaporation should be approximately 55 °C for water and 45 °C for other solvents. For high boiling (> 150 °C) or relatively non-volatile solvents, a vacuum pump should be used. The bath temperature may be raised, if necessary, but should be kept as low as possible. On occasion the bath temperature can be raised above 55 °C to enable evaporation at aspirator pressure. Record the pressure and the bath temperature during evaporation of the eluate.

4. Clean a platinum crucible (volume *ca.* 25 mL) by flaming to red heat over a burner for 10 minutes. When cool, take the crucible, weighing to the nearest 0.0001 g.

5. Quantitatively transfer the concentrate (from step 3) to the tared platinum crucible.
6. Place crucible, loosely covered with a Pyrex evaporating dish, into a circulating air oven maintained at 1 °C above the boiling point of the solvent to effect mass transfer and evaporate to dryness. For solvents with b.p. > 150 °C, or relatively non volatile solvents, place the crucible, loosely covered with a Pyrex evaporating dish, into a vacuum oven maintained at the same temperature as the evaporation bath (cf. Step 3).
7. Weigh the crucible and its contents to the nearest 0.0001 g. Repeat the drying and weighting (steps 6 and 7) at two-hour intervals until no further change in weight is noted. Save the residue for further tests if necessary.
8. Calculate non volatile residue (NVR) as follows:

$$\text{NVR} = [\text{weight dried (Step 7)} - \text{weight crucible (Step 4)}] \times \frac{1500}{1000}$$

9. Calculate non-volatile residue per cartridge as follows:

$$\text{Net NVR} = \text{NVR total (Step 8)} - \text{blank (Step 1)}$$

3. Procedure B – For Sensitive Air Solvents

3.1 Equipment Required

1. 2 liter Pyrex graduated cylinder, cleaned with chromic acid
2. 1500 mL solvent
3. Aluminium foil
4. 12 rpm motor with eccentric cam, having a 75 mm stroke during full cycle, and vertical shaft with hanger
5. Tie rod and plug assembly (see Figure II-1)
6. Dry, oil-free nitrogen supply with needle valve control and inlet tube
7. Rotary evaporator
8. Vacuum pump (optional)
9. Vacuum oven

3.2 Extraction Procedure

1. Fit cartridge with tie rod and plug assembly (see Figure II-1).
2. Fill graduated cylinder to 1500 mL mark with solvent.
3. Immerse cartridge into the measured solvent slowly, allowing all entrained air to escape.
4. Attach shaft of motor to the rod assembly (see Figure II-2).
5. Adjust apparatus so that cartridge is submerged at least 10 mm at downstroke, and emerges at least 20 mm at upstroke.
6. Affix nitrogen inlet tube to inside of graduated cylinder at the top in such a fashion that it will not interfere with the reciprocation. Maintain a slow flow of nitrogen for the duration of the extraction.
7. Cover graduated cylinder with aluminium foil, slotted to accommodate hanger from cam.
8. Reciprocate for 4 hours at room temperature. Extraction at elevated temperatures was not performed with air sensitive solvents.
9. At the end of 4 hours remove filter cartridge from the liquid, allow the solvent to drain into the cylinder, remove the cartridge and cover the graduated cylinder.
10. If further testing of the cartridge is required, the cartridge should be retained, if no immediate testing is required, rinse the cartridge by successively drawing 2000 mL acetone and 2000 mL Fotocol 190 through it, and allow the cartridge to air-dry overnight. When dry, seal the cartridge in a plastic bag.

3.3 Procedure for Determination of Non-volatile Residue

1. Determine a solvent blank by allowing 1500 mL pure solvent to sit in a clean 2 liter graduated cylinder for 4 hours at room temperature under the slow flow of nitrogen and determine the non-volatile residue in the same manner as the following procedure for the filter eluate (i.e. steps 2 – 7 below).
2. Transfer approximately 250 mL of the eluate to a clean container to be used as a retention sample (e.g. in visual examination for haze after dilution with deionized water), allowing 1000 mL to remain in the graduated cylinder. Note that approximately 250 mL of the eluate is retained by the filter cartridge.
3. Clean, using chromic acid, a 1 liter round-bottom flask with a ground-glass joint to fit a rotary evaporator, and dry by flaming. Tare the flask by weighing to the nearest 0.0001 g, preferably, although the nearest 0.001 g is adequate.
4. Evaporate the eluate (1000 mL) to near dryness in the tared flask using the rotary evaporator. Aspirator or vacuum pump pressure should be used as necessary. Bath temperature should be kept at 45 °C, but may be raised, if necessary, keeping it as low as possible. Record the pressure and the bath temperature during evaporation of the eluate. At the end of the evaporation period there should be no drops or other evidence of solvent in the flask.

5. Dry the flask (with residue) in a vacuum oven set at 45 °C, or the same temperature as the bath in Step 4. Weigh the flask with the residue to the nearest milligram or tenth of a milligram (i.e. the same accuracy as in Step 3). Repeat the drying and weighing (Steps 5 and 6) until no change in weight is observed. Save the residue for further tests, if necessary.
6. Calculate non volatile residue (NVR) as follows:

$$\text{NVR} = [\text{weight dried (Step 6)} - \text{weight flask (Step 3)}] \times \frac{1500}{1000}$$

Calculate net non volatile residue per cartridge as follows:

$$\text{Net NVR} = \text{NVR total (Step 7)} - \text{blank (Step 1)}.$$

Notes

Notes

Notes

Notes



Life Sciences

2200 Northern Boulevard
East Hills, New York 11548-1289

800.717.7255 toll free
516.484.5400 phone
516.801.9548 fax
biotech@pall.com e-mail

Europa House, Havant Street
Portsmouth PO1 3PD, United Kingdom
+44 (0)23 9230 3303 phone
+44 (0)23 9230 2506 fax
BioPharmUK@europe.pall.com e-mail



Pall has the most comprehensive
family of scaleable separation products.

Visit us on the web at www.pall.com/biopharmaceutical

Pall Corporation has offices and plants throughout the world in locations including: Argentina, Australia, Austria, Belgium, Brazil, Canada, China, France, Germany, India, Indonesia, Ireland, Italy, Japan, Korea, Malaysia, Mexico, the Netherlands, New Zealand, Norway, Poland, Puerto Rico, Russia, Singapore, South Africa, Spain, Sweden, Switzerland, Taiwan, Thailand, United Kingdom, the United States and Venezuela. Distributors are located in all major industrial areas of the world.

All data, specifications and information contained in this publication are based on information we believe reliable and represent values in effect at the time of printing. Pall Corporation reserves the right to make changes without prior notice. Part Numbers quoted above are protected by the Copyright of Pall Corporation.
© 2008, Pall Europe limited. Filtration. Separation. Solution. is a service mark of Pall Corporation.
 Pall, Ultipor and Posidyne are trade marks of Pall Corporation.
® indicates a registered in the USA, and ™ indicates a common law trademark

PELWR/SM/GN 08.2211/04.2008